

Weyn-Lauwers N.V.

Industriepark-Noord 12
B - 9100 SINT-NIKLAAS

Tel. : 00 32 (0)3 776.34.13
Fax : 00 32 (0)3 778.09.52
weynlauwers@weynlauwers.be
www.weynlauwers.be

EXPANSION JOINT SS BELLOW FIG 976

DESIGN FEATURES

- expansion joint dn25 - dn250 PN16
- Stainless steel bellow
- temp : -20°C +300°C
- specifications :
 - absorbs axial movement
 - with internal liner
 - butt welding steel ends



USE

- for common fluids
- axial movement only
- respect the flow direction indicated by arrow

MATERIALS

item	Part name	Material
1	internal liner	SS 321
2	internal liner	SS 321
3	bellow	SS 321
4	band	SS 321
5	ends	steel St37.2

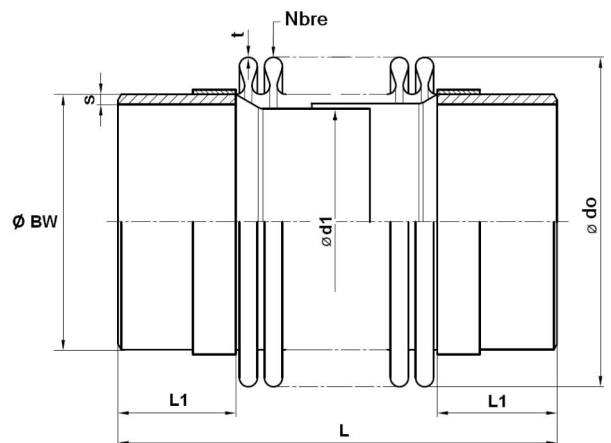
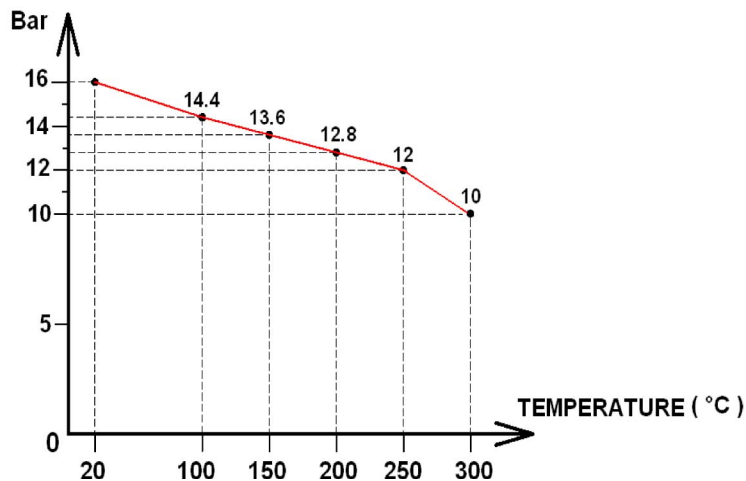
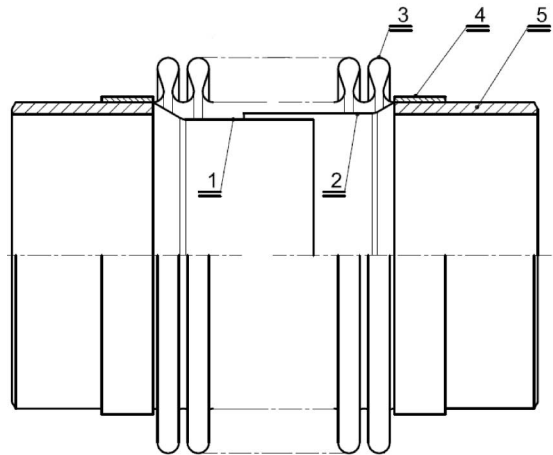

SIZE (in mm)

DN	25	32	40	50	65	80	100	125	150	200	250
L	185	185	200	270	260	275	310	310	350	330	360
L1	55	55	50	75	80	75	60	85	60	65	60
BW	38	42,4	48,3	60,3	76,1	88,9	114,3	139,7	168,3	219,1	273
do	48,8	55,6	61	77	96	112	141	165	201	252	325,8
d1	32	36	41,4	53,5	70	78	103,5	127,3	156	207	261
s	2,6	2,6	2,6	2,9	2,9	3,2	3,6	4	4,5	6,3	6,3
T	0,3	0,3	0,3	0,4	0,5	0,6	0,6	0,6	0,6	0,8	1
wave nbre	17	17	17	20	16	15	20	16	20	16	14
axial movem.	+ -11	+ -10	+ -13	+ -20	+ -20	+ -25	+ -32	+ -33	+ -40	+ -33	+ -40
kg	0,37	0,44	0,53	1,11	1,37	1,86	2,94	3,89	5,85	9,4	13,97
ref.	976.06	976.07	976.08	976.09	976.10	976.11	976.12	976.13	976.14	976.16	976.18