

**Weyn-Lauwers** N.V.

Industriepark-Noord 12  
B - 9100 SINT-NIKLAAS

Tel. : 00 32 (0)3 776.34.13  
Fax : 00 32 (0)3 778.09.52  
weynlauwers@weynlauwers.be  
www.weynlauwers.be

**BALL VALVE  
PP - FULL BORE  
bsp threaded ends  
FIG 140PP**

**DESIGN FEATURES**

- PP ball valve 1/2"-4"
- bsp threaded ends
- min. temp : +10°C
- max. temp : +80°C
- specifications : Full bore



**USE**

- for all common fluids
- max. pressure : 10 bar up to 2 1/2"  
6 bar for 3" - 4"

**MATERIALS**

item	Part name	Material
1	body	PP
5	stem	PP
6	ball	PP
7	ball seat	PTFE
8	body	PP
10	handle	ABS
15	union nut	PP
17	threaded ends	PP
18	cap	ABS
41	stem seat	viton (FPM)
42	body seal	viton (FPM)
43	body seat	viton (FPM)
44	union O-ring	viton (FPM)

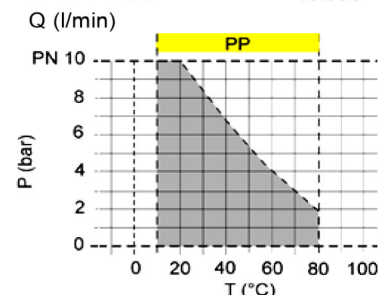
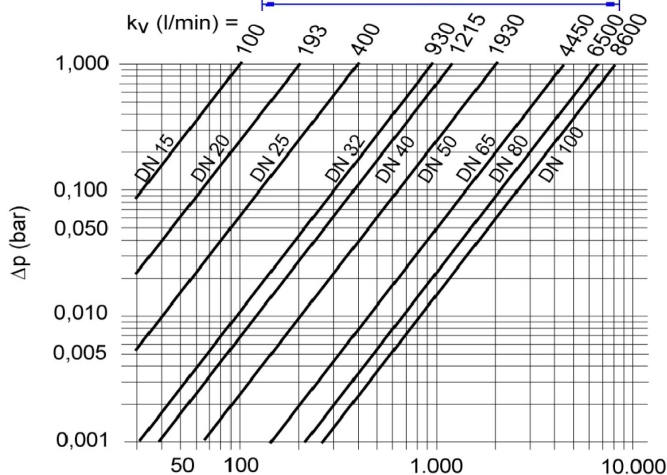
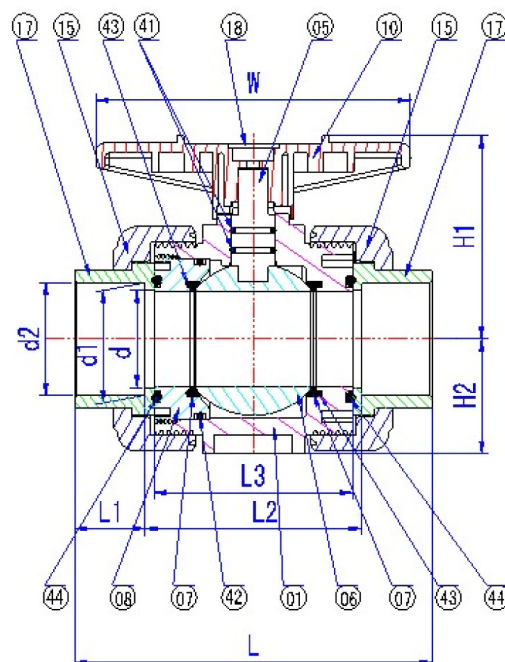

**SIZE (in mm)**

DN	15	20	25	32	40	50	65	80	100
d	20	25	32	40	50	63	75	90	110
bsp	1/2"	3/4"	1"	5/4"	6/4"	2"	2 1/2"	3"	4"
D	54	63	73,5	84,5	98	118	150	169	211
L	92	110	114	130	151,5	171	238,5	268	318
L1	16	19	22	26	32	38	47	51	61
L2	60	62	70	78	87,5	95	114,5	166	196
L3	52	54	62	70	79,5	85	132,5	150	172
N	84	90	106	116	128	140	210	235	260
H1	52,5	59	67,5	77,5	90	106	136,5	149,5	175
H2	27,5	32	37,25	42,75	50	60	76,5	86	107
F	31	33	40	52	52	70	84	84	121
M							45	45	49
ref.	140PP.04	140PP.05	140PP.06	140PP.07	140PP.08	140PP.09	140PP.10	140PP.11	140PP.12

