

Weyn-Lauwers N.V.

Industriepark-Noord 12
B - 9100 SINT-NIKLAAS

Tel. : 00 32 (0)3 776.34.13
Fax : 00 32 (0)3 778.09.52
weynlauwers@weynlauwers.be
www.weynlauwers.be

**BALL VALVE
PVC - FULL BORE
glue ends - EPDM O-rings
FIG 145**

DESIGN FEATURES

- PVC ball valve 1/2"-4"
- glue ends
- min. temp : 0°C
- max. temp : +50°C
- specifications : Full bore



USE

- for all common fluids
- max. pressure : 10 bar up to DN65
6 bar for DN80-DN100

MATERIALS

item	Part name	Material
1	body	PVC
5	stem	PVC
6	ball	PVC
7	ball seat	PTFE
8	body	PVC
10	handle	ABS
15	union nut	PVC
17	glue ends	PVC
18	cap	ABS
41	stem seat	EPDM
42	body seal	EPDM
43	body seat	EPDM
44	union O-ring	EPDM

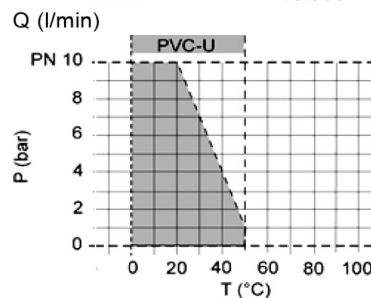
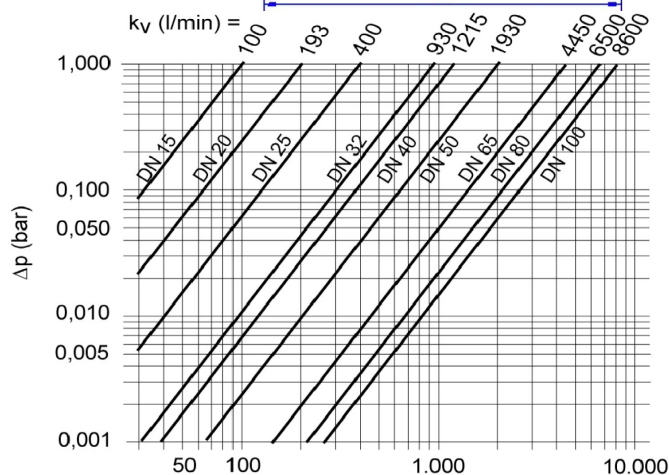
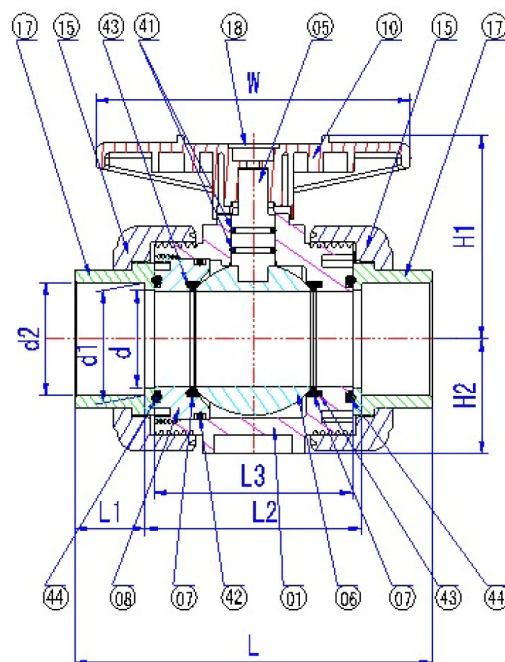

SIZE (in mm)

DN	15	20	25	32	40	50	65	80	100
d	20	25	32	40	50	63	75	90	110
d1	20,3	25,3	32,3	40,3	50,3	63,3	75,3	90,4	110,4
d2	20,1	25,1	32,1	40,1	50,1	63,1	75,1	90,1	110,1
D	54	63	73,5	84,5	98	118	150	169	211
L	92	110	114	130	151,5	171	238,5	268	318
L1	16	19	22	26	32	38	47	51	61
L2	60	62	70	78	87,5	95	114,5	166	196
L3	52	54	62	70	79,5	85	132,5	150	172
N	84	90	106	116	128	140	210	235	260
H1	52,5	59	67,5	77,5	90	106	136,5	149,5	175
H2	27,5	32	37,25	42,75	50	60	76,5	86	107
F	31	33	40	52	52	70	84	84	121
M							45	45	49
ref.	145.04	145.05	145.06	145.07	145.08	145.09	145.10	145.11	145.12

