



Weyn-Lauwers N.V.

Industriepark-Noord 12
B - 9100 SINT-NIKLAAS

Tel. : 00 32 (0)3 776.34.13
Fax : 00 32 (0)3 778.09.52
weynlauwers@weynlauwers.be
www.weynlauwers.be

**WAFER BALL VALVE
THREADED HOLE FLANGES
CAST IRON PN16
fig 181T.0**

DESIGN FEATURES

- **wafer type ball valve** dn40 - dn100
- temp : -10°C +150°C
- specifications :
installation between flanges PN10/16
flanges with threaded holes
full bore - anti blow-out stem

USE

- common fluids
- do not use with steam
- max. pressure : 16 bar

MATERIALS

item	Part name	Material
1	body	cast iron EN GJL-250
2	ends	cast iron EN GJL-250
3	seat	PTFE
4	ball	chromed brass
5	stem	brass CW 614N
6	packing	PTFE
7	packing nut	brass CW 614N
8	O-ring	NBR
9	handle	steel
10	handle nut	steel

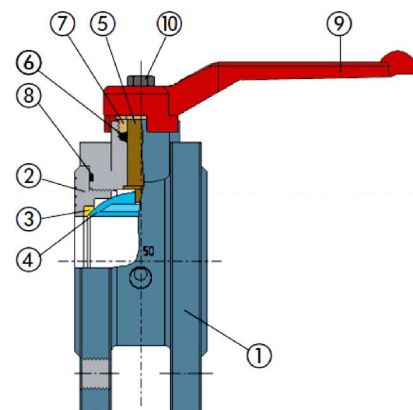
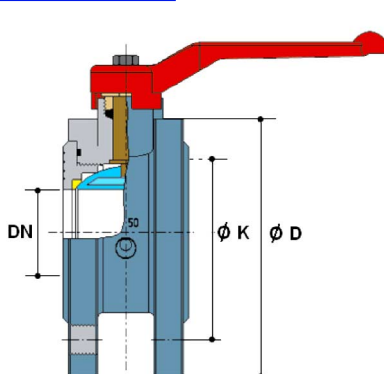
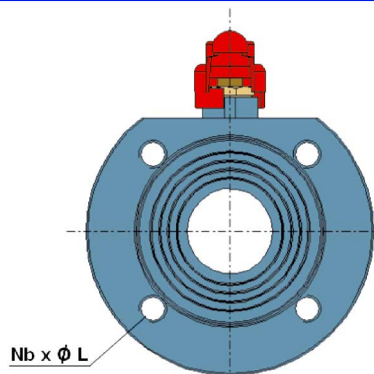
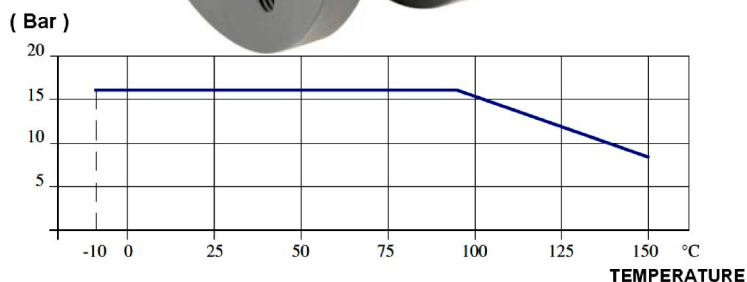

SIZE (in mm)

DN	40	50	65	80	100
P	40	50	61	74	95
L	62	72	94	118	140
E	150	150	240	240	260
H	105	112	144	154	144
D	150	165	185	200	220
K	110	125	145	160	180
NbxL	4xM16	4xM16	4xM16	8xM16	8xM16
kg	4,07	5,53	7,60	10,23	13,5
Kv (m3/h)	170	265	510	790	1230
ref.	181T.0.08	181T.0.09	181T.0.10	181T.0.11	181T.0.12

