

Weyn-Lauwers N.V.

Industriepark-Noord 12
B - 9100 SINT-NIKLAAS

Tel. : 00 32 (0)3 776.34.13
Fax : 00 32 (0)3 778.09.52
weynlauwers@weynlauwers.be
www.weynlauwers.be

3-WAY BALL VALVE REDUCED BORE - SS T-PORT FIG 187

DESIGN FEATURES

- SS316 3-way ball valve reduced bore
- temp : -25°C +180°C
- specifications :
 - anti-static device (ball-stem-body)
 - locking device
 - blow-out proof stem
 - PN 63
 - direct mounting pad acc. ISO 5211
 - thread ends acc. DIN2999

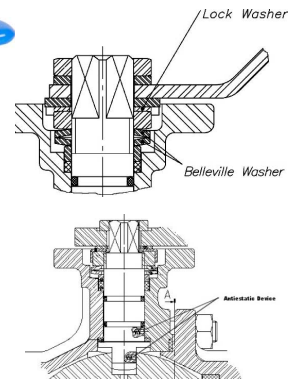

MATERIALS

item	Part name	Material
1	body	SS 316
2	cap	SS 316
3	ball	SS 316
4	ball seat	PTFE + 15 % GF
5	stem	SS 316
6	anti-static device	SS 316
7	trust washer	PTFE
8	O-ring	viton
9	stem packing	PTFE
10	bushing	SS + PTFE
11	stem ring	SS 316
12	spring washer	SS 301
13	nut	ASTM A 194-8
14	stopper	SS 304
15	washer	SS 304
16	handle nut	SS 304
17	handle sleeve	vynil
18	handle	SS 304
19	lock device	SS 304
20	gasket	PTFE
21	stop bolt	SS 304
22	nut	ASTM A 194-8

Flow pattern

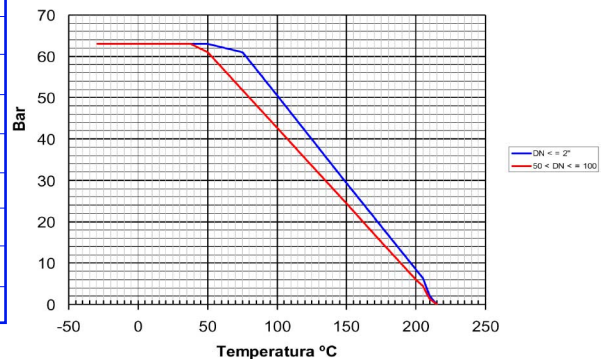
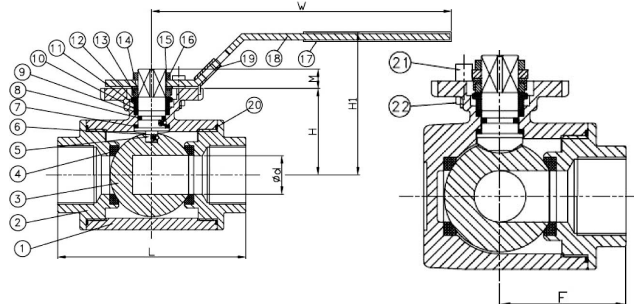
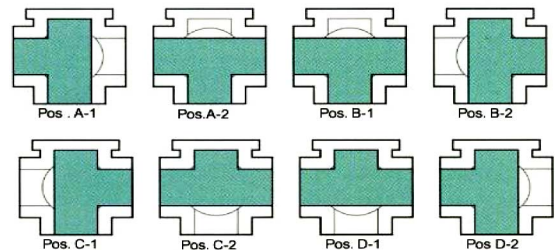

SIZE (in mm)

DN	1/4"	3/8"	1/2"	3/4"	1"	1 1/4"	1 1/2"	2"	2 1/2"
PN	63	63	63	63	63	63	63	63	63
d	9,5	11	12	15	20	25	32	40	49
L	75	75	75	88	100	122	131	158	178
H	37	37	37	41	47	56	60	71	95
H1	66	66	66	72	77	92	96	107	135
W	130	130	130	161	161	203	203	203	254
M	7	7	7	7	7	7	12	12	14
F	37	37	37	42	50	61	65	79	89
ISO	F03/F04	F03/F04	F03/F04	F04/F05	F04/F05	F05/F07	F05/F07	F05/F07	F07/F10
kg	0,70	0,67	0,63	0,95	1,40	2,90	3,60	6,25	8,72
ref.	204260	204261	204262	204263	204264	204265	204266	204267	187.10