



Weyn-Lauwers N.V.

INDUSTRIEPARK-NOORD 12
B - 9100 SINT-NIKLAAS

TEL. 0032 (0)3 776.34.13
FAX. 0032 (0)3 778.09.52

weynlauwers@weynlauwers.be
www.weynlauwers.be

KOGELKRAAN
3-WEG PN 16
GG25
fig 190L / 190T

KENMERKEN

- geflensd volgens DIN 3202
- fig190L : L-boring
- fig190T : T-boring
- niet uitdrukbare spindel
- volle doorlaat
- opbouwflens volgens ISO 5211
- -10 'C tot +180'C

MATERIALEN

1	huis	gietijzer	GG-25
10	kogel	RVS	1.4308
12	spindeldichting	PTFE	
17	drukkring	gietijzer	GG-25
19	deksel	gietijzer	GG-25
20	bout	staal	8.8
39	kogelafdichting	PTFE	
45	huisafdichting	PTFE	
46	bout	staal	8.8
50	hendel	gietijzer	GG-25

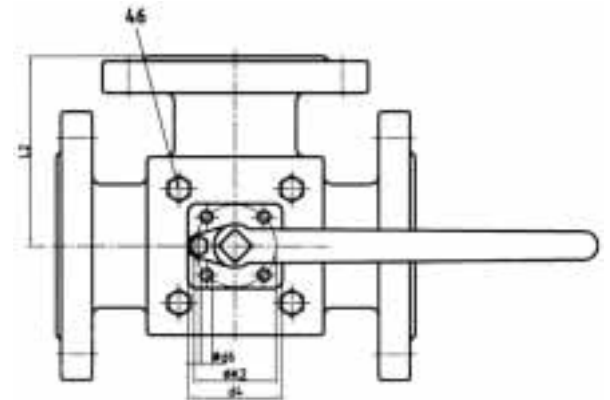
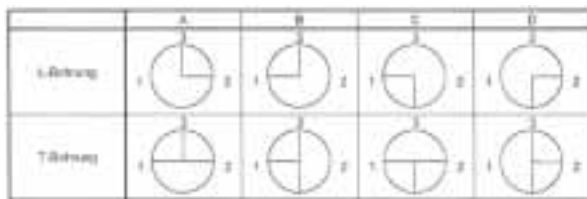
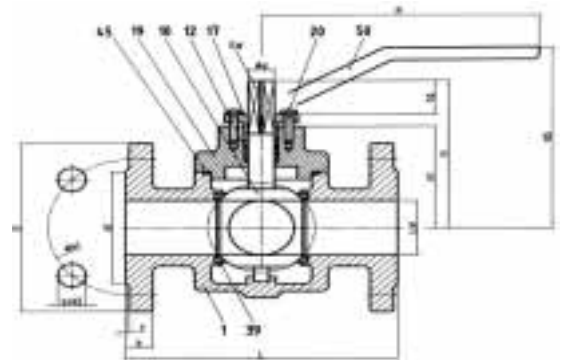

AFMETINGEN

DN	LW	L	L2	H	H5	h1	h2	d	d1	d2	d4	d6	SW	k1	k2	R	D	b	f	z	kg	iso	torque Nm	Cv
25	25	180	90	103	135	73	17	16	67	18	55	M6	12	85	50	175	125	15	1	4	9,5	F05	24	16
40	39	190	95	133	135	83	28	21,5	86	18	70	M8	16	110	70	235	150	16	1	4	13,0	F07	45	30
50	49	220	110	136	135	86	37	21,5	100	18	85	M8	18	125	70	235	165	16	1	4	17,0	F07	61	50
65	63	250	125	146	210	93	37	25	120	18	95	M10	19,5	145	102	340	185	18	1	4	27,0	F10	100	140
80	74	260	130	156	210	103	37	25	130	20	100	M10	19,5	160	102	340	200	18	1	8	29,0	F10	145	260
100	100	340	170	172	210	122	34	25	155	18	100	M10	19,5	180	102	340	220	20	1	8	45,0	F10	200	410
150	150	455	228	240	240							M12				510					103	F12	550	750