

Weyn-Lauwers N.V.

Industriepark-Noord 12
B - 9100 SINT-NIKLAAS

Tel. : 00 32 (0)3 776.34.13
Fax : 00 32 (0)3 778.09.52
weynlauwers@weynlauwers.be
www.weynlauwers.be

**KNIFE GATE VALVE
CAST IRON - PN10
FIG 380**

DESIGN FEATURES

- cast iron knife gate valve dn50 - dn700 PN10
- temp : -10°C +80°C
- specifications :
 - non-rising and handwheel unidirectional tightness with handwheel
 - option : lever or chain handwheel

USE

- water, water treatment, chemical pulp
- powders, food industry, chemistry
- for powders, inverse flow direction

MATERIALS

item	Part name	Material
1	body	cast iron EN GJL-250
2	gate	SS 304
3	packing gland nut dn50-200 : aluminium	
3	packing gland nut dn250-700 : cast iron	
4	seat	NBR
5	support	painted steel
6	retainer	SS 304
7	packing (tress)	PTFE
8	packing (O-ring)	NBR
9	yoke	steel
10	oil hole	steel
11	fixing screw	steel
12	hood	steel
13	hood cover	plastic
14	spindle	SS 303
15	stem nut	bronze
16	handwheel	steel
17	washer	brass

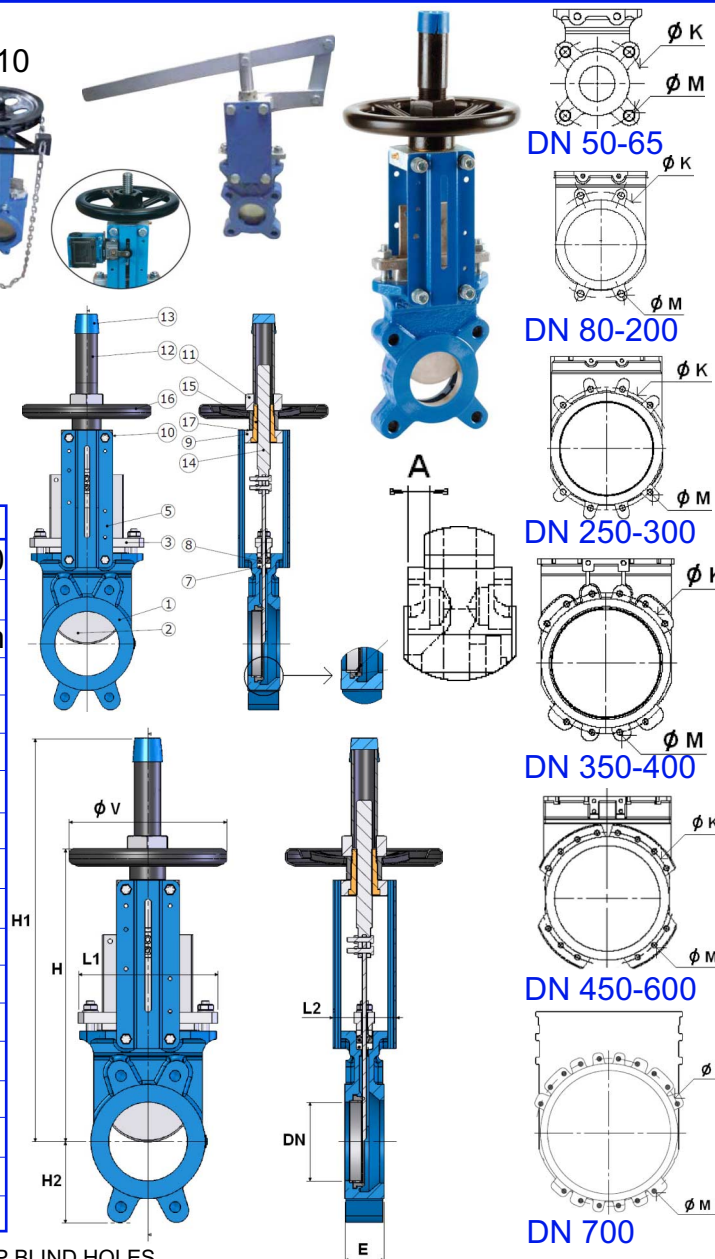

SIZE (in mm)

A = THREADED LENGHT FOR TOP BLIND HOLES

DN	50	65	80	100	125	150	200	250	300	350	400	500	600	700
Pmax(bar)	10	10	10	10	10	10	10	8	6	4	4	3	3	2
E	40	40	50	50	50	60	60	70	70	96	100	110	110	110
H	289	316	342	382	415	458	575	676	776	906	1012	1210	1416	1611
H1	409	436	462	502	585	637	815	1016	1116	1336	1442	1740	2046	2461
H2	63	70	92	105	120	130	160	198	234	256	292	340	400	452
L1	124	139	154	174	192	217	270	326	380	438	493	620	714	830
L2	92	92	92	92	102	102	119	119	119	290	290	290	290	320
V	185	185	185	185	225	225	325	325	380	450	450	450	450	620
K	125	145	160	180	210	240	295	350	400	460	515	620	725	840
M	M16	M16	M16	M16	M16	M20	M20	M20	M20	M20	M24	M24	M27	M27
A	8	8	9	9	9	10	10	12	12	20	20	22	22	22
kg	6,53	7,1	8,53	9,8	12,7	16,16	26,8	43,5	57,5	108	132	210	298	446
ref.	204120	204121	204122	204123	204124	204125	204126	204127	204128	204129	204130	204132	204133	204134