

Weyn-Lauwers N.V.

Industriepark-Noord 12
B - 9100 SINT-NIKLAAS

Tel. : 00 32 (0)3 776.34.13
Fax : 00 32 (0)3 778.09.52
weynlauwers@weynlauwers.be
www.weynlauwers.be

**KNIFE GATE VALVE
SS 316 - PN10
FIG 380I**

DESIGN FEATURES

- **stainless steel** knife gate valve dn50 - dn400 PN10
- temp : -15°C +110°C
- specifications :
 - non-rising and handwheel unidirectional tightness with handwheel
 - option : lever or chain handwheel

USE

- water, water treatment, chemical pulp
- powders, food industry, chemistry
- for powders, inverse flow direction

MATERIALS

item	Part name	Material
1	body	ASTM A351 CF8M
2	gate	SS 316
3	packing gland nut	dn50-200 : CF8M
3	packing gland nut	dn250-400 : CF8M
4	seat	EPDM
5	support	painted steel
6	retainer	SS 316
7	packing (tress)	PTFE
8	packing (O-ring)	EPDM
9	yoke	steel
10	oil hole	steel
11	fixing screw	steel
12	hood	steel
13	hood cover	plastic
14	spindle	SS 303
15	stem nut	bronze
16	handwheel	steel
17	washer	brass

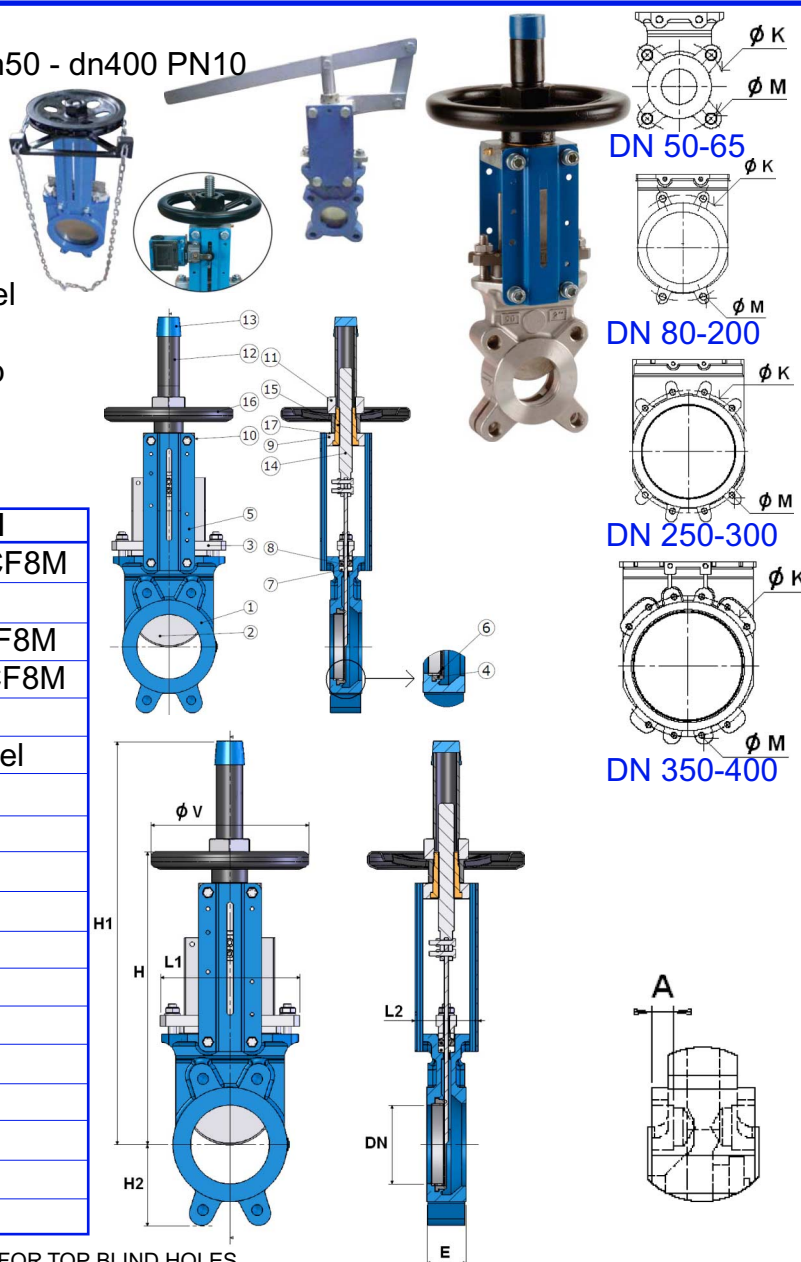

SIZE (in mm)

A = THREADED LENGHT FOR TOP BLIND HOLES

DN	50	65	80	100	125	150	200	250	300	350	400			
Pmax(bar)	10	10	10	10	10	10	10	8	6	4	4			
E	40	40	50	50	50	60	60	70	70	96	100			
H	289	316	342	382	415	458	575	676	776	906	1012			
H1	409	436	462	502	585	637	815	1016	1116	1336	1442			
H2	63	70	92	105	120	130	160	198	234	256	292			
L1	124	139	154	174	192	217	270	326	380	438	493			
L2	92	92	92	92	102	102	119	119	119	290	290			
V	185	185	185	185	225	225	325	325	380	450	450			
K	125	145	160	180	210	240	295	350	400	460	515			
M	M16	M16	M16	M16	M16	M20	M20	M20	M20	M20	M24			
A	8	8	9	9	9	10	10	12	12	20	20			
kg	6,53	7,1	8,53	9,8	12,7	16,16	26,8	43,5	57,5	108	132			
ref.	204160	204161	204162	204163	204164	204165	204166	204167	204168	204169	204170			