

Weyn-Lauwers N.V.

Industriepark-Noord 12
B - 9100 SINT-NIKLAAS

Tel. : 00 32 (0)3 776.34.13
Fax : 00 32 (0)3 778.09.52
weynlauwers@weynlauwers.be
www.weynlauwers.be

**SLANTED SEAT
GLOBE VALVE SS316
PNEUMATIC NC
FIG531II**

DESIGN FEATURES

- gas threaded ends acc. DIN 2999
- Also available with NPT thread (fig 531II NPT)
- PN 16
- construction : stainless steel AISI 316
- spring return actuator normally closed
- actuator seal : NBR
- working temp. range : -10°C +180°C
- pressure control actuator : 3-10 bar

USE

- for all common fluids

MATERIALS

item	Part name	Material
1	Valve (Body)	SS CF8M (316)
2	Seat	PTFE
3	Stem (Valve)	stainless steel 316
4	Sealing Part	PTFE
5	Joint Hole	G 1/8"
6	Actuator	Stainless steel 304
7	Spring	Spring Steel
8	Position Indicator	Plastic
9	Piston	Aluminium Alloy
10	Piston Ring	FKM (Viton)
11	Spring	Stainless steel 304
12	Connection Part	SS CF8M (316)
13	Body Seal	PTFE
14	Port connection	SS CR8M (316)

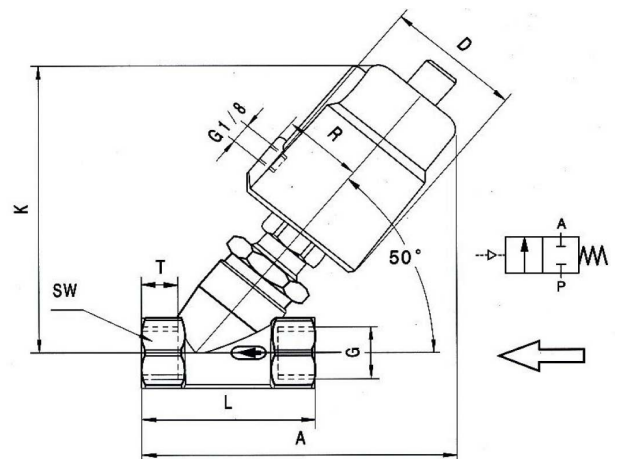
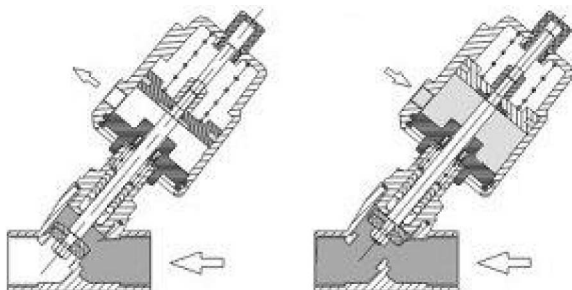
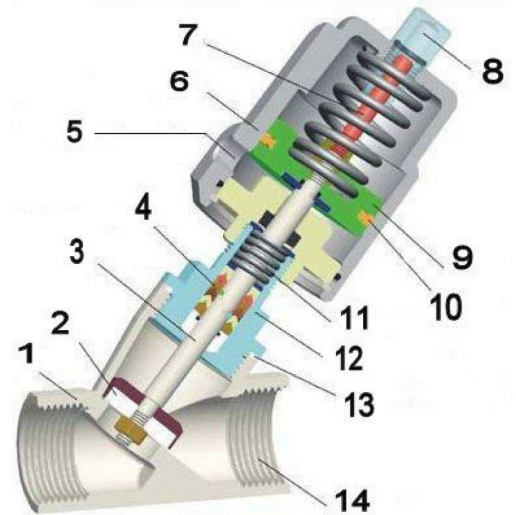

Spring return actuator, Normally closed (NC)

SIZE (in mm)

DN	1/2"	3/4"	1"	1 1/4"	1 1/2"	2"
A	133	137	149	188	190	203
K	126	131	140	175	178	184
L	68	75	90	116	120	138
D	60	60	60	77	77	77
ref.	207270	207271	207272	207273	207274	207275