



**Weyn-Lauwers** N.V.

INDUSTRIEPARK-NOORD 12  
B - 9100 SINT-NIKLAAS

TEL. 0032 (0)3 776.34.13  
FAX. 0032 (0)3 778.09.52

weynlauwers@weynlauwers.be  
www.weynlauwers.be

SCHUIFAFSLUITER  
fig 331 - GG25  
SNELSLUITER  
PN 10

**SCHNELLSCHLUß-SCHIEBER** **GG-25** **PN 10**  
**QUICK-CLOSING GATE VALVE**

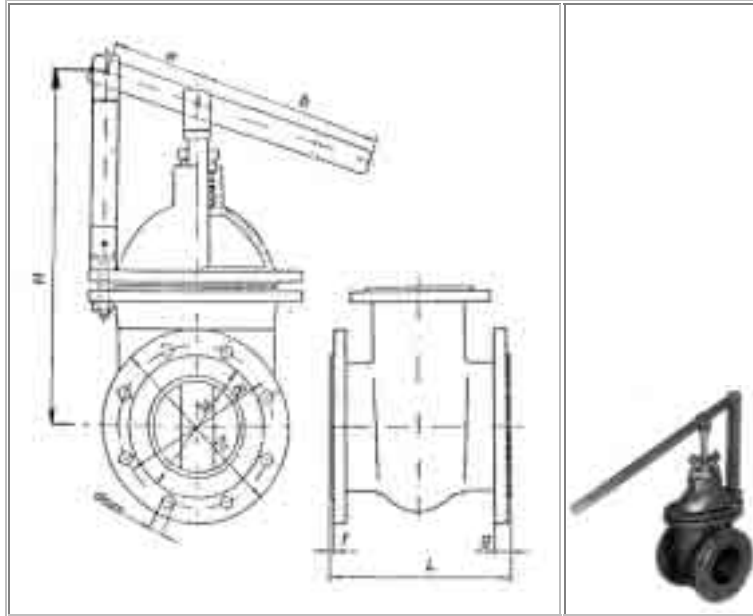

FÜR NICHTAGGRESSIVE MEDIEN  
FLANSCHBOHRUNG NACH DIN 2501  
BAULÄNGE NACH DIN 3202 F4

FOR NON-AGRESSIVE MEDIA  
FLANGE DRILLED ACC. TO DIN 2501  
F-TO-F DIMENSION DIN 3202 F4

TEMPERATUR MAXIMAL 150<sup>0</sup> C  
BETRIEBSDRUCK MAXIMAL 10 BAR

WORKING TEMPERATURE MAX. 150<sup>0</sup>  
WORKING PRESSURE MAX. 10 BAR

AUCH IN PN 16 ERHÄLTICH

ALSO AVAILABLE AS PN 16

GEHÄUSE, DECKEL, KEIL	GG-25 / DIN 1691	BODY, BONNET, WEDGE
SPINDEL	X20Cr13	STEM
SITZE	MESSING / BRASS	SEATS
HEBEL	STAHL / STEEL	LEVER
DICHTUNG	O-RING	PACKING

DN	DZ	D <sub>0</sub>	DP	L	H	G	N	D <sub>0</sub>	F	A	B	KG
40	150	110	88	140	310	18	4	18	3	70	350	
50	165	125	102	150	335	20	4	18	3	80	370	13,4
65	185	145	122	170	350	20	4	18	3	95	400	18,6
80	200	160	138	180	400	22	8	18	3	110	420	22,5
100	220	180	158	190	440	22	8	18	3	118	460	28,2
125	250	210	188	200	500	24	8	18	3	140	500	36,5
150	285	240	212	210	560	24	8	22	3	160	550	44,4
200	340	295	268	230	700	26	8	22	3	200	600	75,0
250	395	350	320	250	725	28	12	22	3	240	650	100,0
300	445	400	370	370	830	28	12	22	4	265	700	144,0

ABBILDUNGEN UND MATERIALANGABEN SIND UNVERBINDLICH  
DESIGN AND MATERIALS CAN BE CHANGED WITHOUT NOTICE  
IRRTUM VORBEHALTEN - ERRORS AND OMISSIONS EXCEPTED