

Weyn-Lauwers N.V.

Industriepark-Noord 12
B - 9100 SINT-NIKLAAS

Tel. : 00 32 (0)3 776.34.13
Fax : 00 32 (0)3 778.09.52
weynlauwers@weynlauwers.be
www.weynlauwers.be

**CHECK VALVE
BRASS
FIG 704**

FEATURES



- monobloc (up to 2") check valve PN25/12
- hot-forging brass according to UNE-EN 10165
- ends : female gas threads acc. to ISO 228/1
- max. working temparture :
 - air : -20 C to 110 C
 - gas : -20 C to 60 C
 - water : 0 C to 90 C
- minimum starting pressure 0,04 bar
- suitable for all kind op industrial, pneumatic and hydraulic installations
- multipositional settings (horizontal, vertical and oblique)
- vulcanized NBR gasket plate

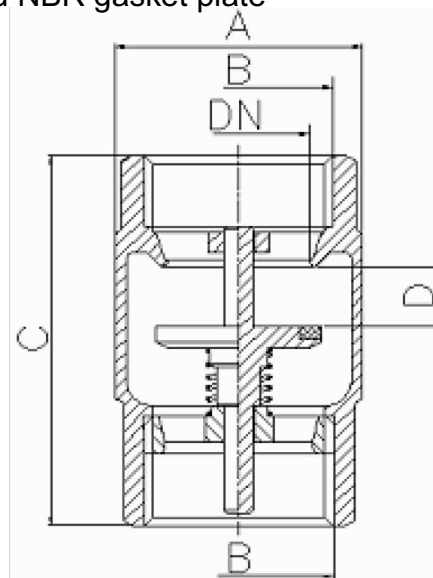
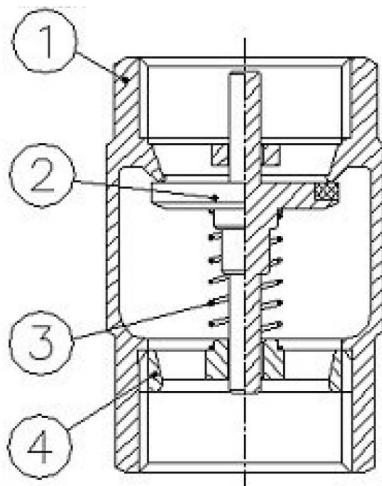

Nr.	Name	Material	Surface treatment
1	Body	Brass	Peened + machining
2	Plate	Brass + NBR	Peened + machining + Vulcanized
3	Spring	AISI 304	
4	Ring	Brass	Peened + machining

art.nr.	Size B	DN	PN	Dimensions (mm)			Weight g.
				diam. A	C	D	
207370	G 1/2"	15	25	30	50	7,5	110
207371	G 3/4"	20	25	36,5	57	8,5	180
207372	G 1"	25	25	43	65	10,5	260
207373	G 1 1/4"	32	18	53	70	11	380
207374	G 1 1/2"	40	18	64,5	75,5	12	525
207375	G 2"	50	18	79,5	81,5	14	800
207376	G 2 1/2"	65	12	104	104	22	1660
207377	G 3"	80	12	124	113	23	2365
207378	G 4"	100	12	155	132	27	3935