



Weyn-Lauwers N.V.

Industriepark-Noord 12
B - 9100 SINT-NIKLAAS

Tel. : 00 32 (0)3 776.34.13
Fax : 00 32 (0)3 778.09.52
weynlauwers@weynlauwers.be
www.weynlauwers.be

SWING CHECK VALVE BRASS - FF - METAL FIG 710T

DESIGN FEATURES

- brass swing check valve PN10
- max. temp : +200°C
- specifications :
 - brass according DIN 17660
 - thread ends gas female-female cylindric BSP
- also available with NPT thread ends (fig 710NPT)



MATERIALS

item	Part name	Material
1	body	brass EN 12165
2	disc	brass EN 12165
3	bonnet gasket	fiber
4	bonnet	brass EN 12165
5	stem	brass Hpb59-1
6	stem screw	brass Hpb59-1

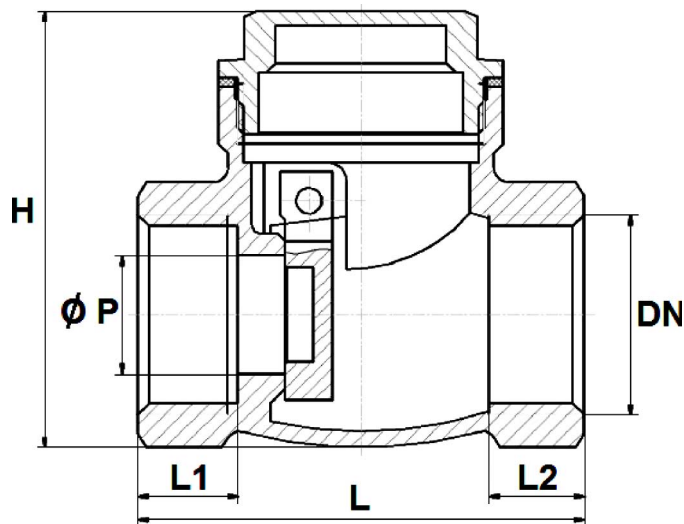
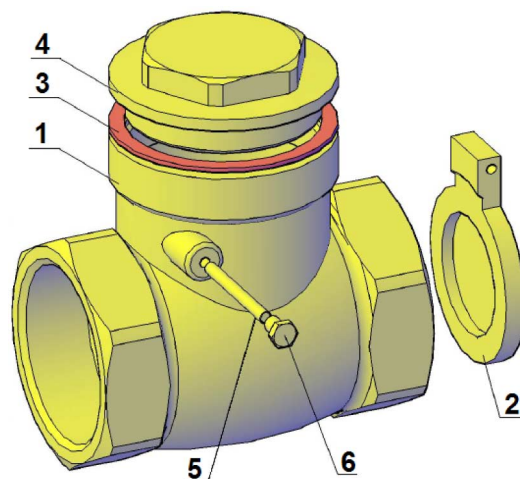

SIZE (in mm)

DN	3/8"	1/2"	3/4"	1"	1 1/4"	1 1/2"	2"	2 1/2"	3"	4"
P	12	12,5	18,5	23,5	30	35	47	55	68	88
L	47	47	53	63	70	88	97	116	135	164
L1	10,5	10,5	12	13,5	17	18	19,5	16	16	20
L2	10,5	10	12	12	14,5	17	19,5	16	16	20
H	46	46	52	62	73	92	102	113	133	166
kg	0,12	0,14	0,20	0,34	0,43	0,76	1,00	1,57	1,88	3,77
ref.	205311	205312	205313	205314	205315	205316	205317	710T.10	710T.11	710T.12