

**Weyn-Lauwers** N.V.

Industriepark-Noord 12  
B - 9100 SINT-NIKLAAS

Tel. : 00 32 (0)3 776.34.13  
Fax : 00 32 (0)3 778.09.52  
weynlauwers@weynlauwers.be  
www.weynlauwers.be

## SWING CHECK VALVE BRASS - FF - EPDM FIG 711T

### DESIGN FEATURES

- brass swing check valve PN10
- max. temp : +90°C
- specifications :
  - brass according DIN 17660
  - thread ends gas female-female cylindric BSP
- also available with NPT thread ends (fig 711NPT)



### MATERIALS

item	Part name	Material
1	body	brass EN 12165
2	disc	brass EN 12165
3	gasket	EPDM
4	screw	brass Hpb59-1
5	bonnet gasket	fiber
6	bonnet	brass EN 12165
7	stem	brass Hpb59-1
8	stem screw	brass Hpb59-1

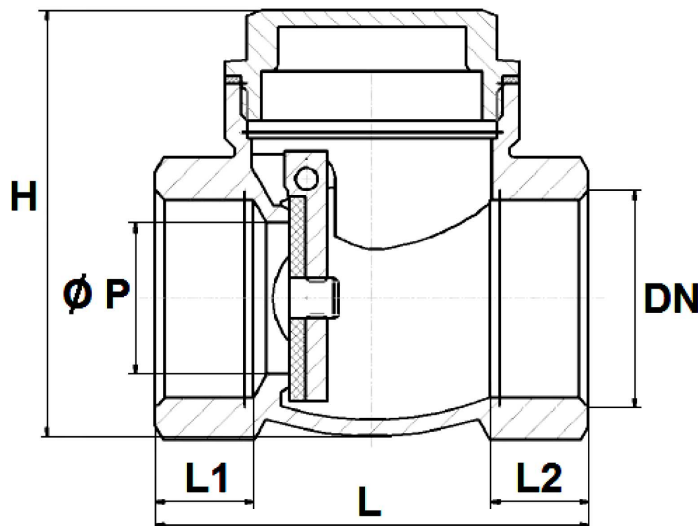
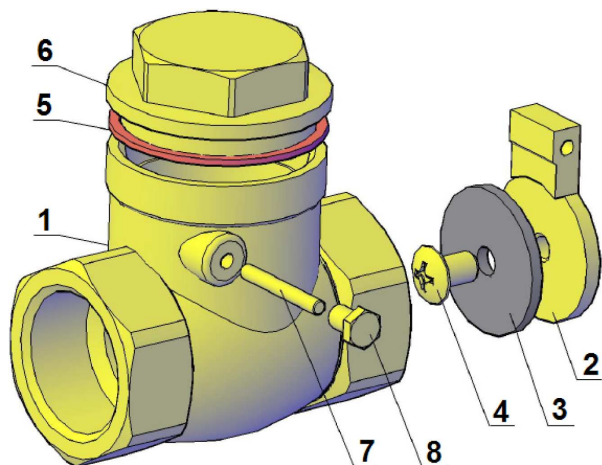

### SIZE (in mm)

DN		3/8"	1/2"	3/4"	1"	1 1/4"	1 1/2"	2"	2 1/2"	3"	4"
P		12,5	12,5	18,5	23,5	30	35	47	55	68	88
L		47	47	53	63	70	88	97	116	135	164
L1		10,5	10,5	12	13,5	17	18	19,5	16	16	20
L2		10,5	10	12	12	14,5	17	19,5	16	16	20
H		46	46	52	62	73	92	102	113	133	166
kg		0,12	0,14	0,20	0,34	0,43	0,76	1,00	1,58	2,26	3,84
ref.		205322	205323	205324	205325	205326	205327	205328	205329	205330	205331