



Weyn-Lauwers N.V.

INDUSTRIEPARK-NOORD 12
B - 9100 SINT-NIKLAAS

TEL. 0032 (0)3 776.34.13
FAX. 0032 (0)3 778.09.52

weynlauwers@weynlauwers.be
www.weynlauwers.be

SWING CHECK VALVE
PN 16 - PN 25
GS-C25

RÜCKSCHLAGKLAPPEN	GS-C25	FIG. 755	PN 16
SWING CHECK VALVES		FIG. 756	PN 25

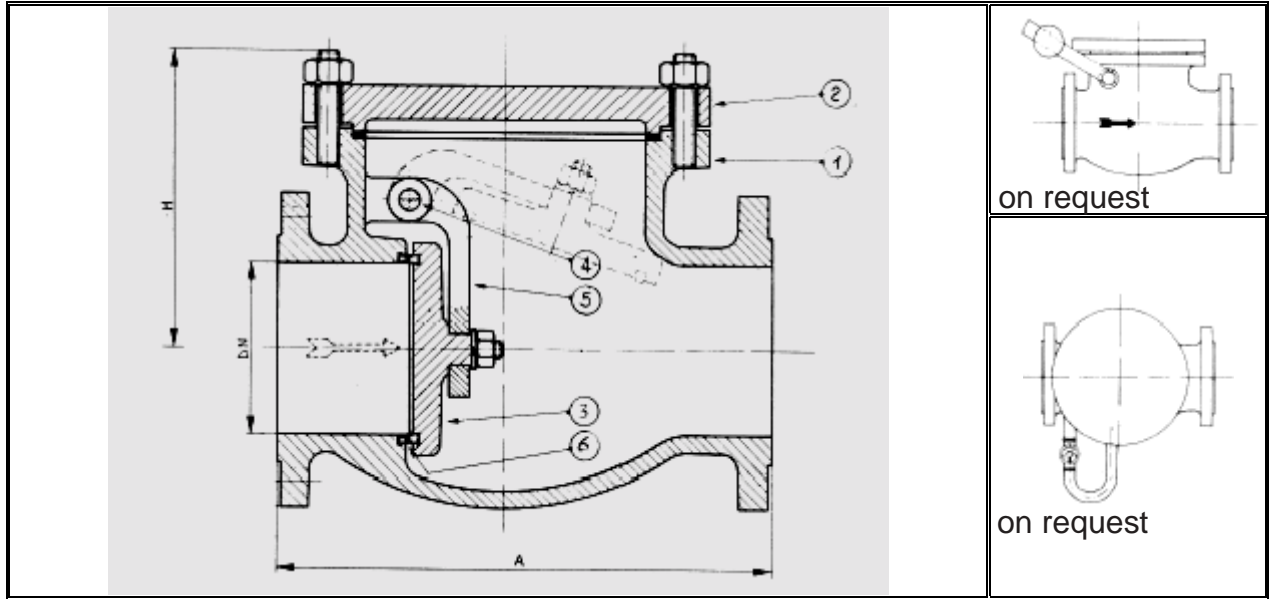

MATERIAL	MATERIALS
1. - 2. - 3. - 5.	GS-C25
4.	420
6.	304

DN		40	50	65	80	100	125	150	200	250	300	350	400	450	500	600
A		180	200	240	260	300	350	400	500	600	700	800	900	1000	1100	1300
H		220	230	280	300	330	380	400	450	520	570	650	690	710	800	950
KG	PN 16	16	21	26	36	55	90	128	206	290	326	400	455			
KG	PN 25	20	22	29	38	57	92	130	210	294	367	416	461			

ABBILDUNGEN UND MATERIALANGABEN SIND UNVERBINDLICH
DESIGN AND MATERIALS CAN BE CHANGED WITHOUT NOTICE
IRRTUM VORBEHALTEN - ERRORS AND OMISSIONS EXCEPTED
REL.120701