



Weyn-Lauwers N.V.

INDUSTRIEPARK-NOORD 12
B - 9100 SINT-NIKLAAS

TEL. 0032 (0)3 776.34.13
FAX. 0032 (0)3 778.09.52

weynlauwers@weynlauwers.be
www.weynlauwers.be

**SWING CHECK
VALVE**

**fig 758 - A216WCB
ANSI 150 Lbs**

ANSI-RÜCKSCHLAGKLAPPEN **150 LBS** **FIG. 758**
ANSI-SWING CHECK VALVES

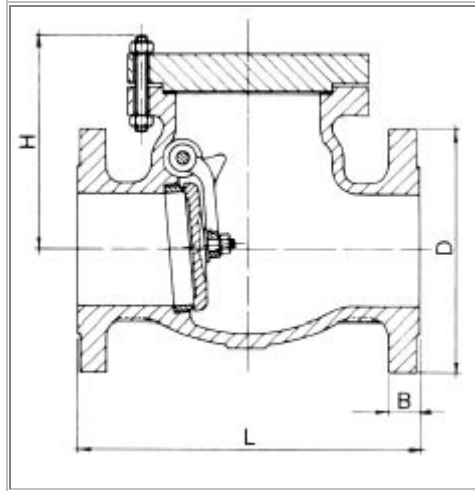

BESCHREIBUNG	DESCRIPTION
DESIGN NACH API 600 STANDARD	DESIGN PER API 600 STANDARDS
TESTS NACH API 598 STANDARD	TESTS PER API 598 STANDARDS
BAULÄNGE NACH ANSI B16.10	F-TO-F DIMENSIONS ANSI B16.10
FLANSCH NACH ANSI B 16.5	FLANGED ENDS ACC. TO ANSI B 16.5

TESTS	TESTS
HYDAULISCH: GEHÄUSE 425 PSIG (29,9BAR)	HYDRAULIC TEST PRESSURE: BODY 425 PSIG
SITZE 275 PSIG (19,3 BAR)	SEATS 275 PSIG
LUFT: SITZE 60-100 PSIG (4,2-7 BAR)	AIR TEST PRESSURE: SEATS 60-100 PSIG

BESCHREIBUNG	MATERIAL	BESCHREIBUNG	MATERIAL
BODY	A216WCB	HINGE PIN	A182F6
COVER	A216WCB	PLUG	A105
DISC	A182F6 ≤6" >13% CR-FACED	GASKET	ASBESTOS-FREE
SEAT RING	A182F6	COVER STUD /BOLT NUTS	A193 B7-A194 2H
HINGE	A 105		

DIMENSIONS (MM)

DN	50	65	80	100	150	200	250	300	350	400	450	500	600
INCH	2	2 1/2	3	4	6	8	10	12	14	16	18	20	24
L	203	216	241	292	356	495	622	699	787	864	978	978	1295
D	152	178	191	229	280	343	406	483	533	597	635	699	813
B	16	17,5	19	24	25,5	28,5	30,5	32	35	36,5	40	43	48
H	140	160	175	205	260	305	365	410	435	500	570	640	720

ABBILDUNGEN UND MATERIALANGABEN SIND UNVERBINDLICH
DESIGN AND MATERIALS CAN BE CHANGED WITHOUT NOTICE
IRRITUM VORBEHALTEN - ERRORS AND OMISSIONS EXCEPTED
REL.100401