



Weyn-Lauwers N.V.

Industriepark-Noord 12
B - 9100 SINT-NIKLAAS

Tel. : 00 32 (0)3 776.34.13
Fax : 00 32 (0)3 778.09.52
weynlauwers@weynlauwers.be
www.weynlauwers.be

**SWING CHECK VALVE
CARBON STEEL
fig 782B**

DESIGN FEATURES

- **wafer type swing check valve** dn40 - dn600 PN10/16
- temp : -10°C +80°C
- specifications :
 - assembly between flanges PN10-PN16
 - installed with vertical or horizontal flow
 - reduced bore
 - galvanised carbon steel body / **O-rings in NBR**
 - do not use with pulsatory speed

USE

- for all common fluids / max. speed 3 m/sec
- 16 bar up to dn200 / 10 bar for dn250 - dn600

MATERIALS

item	Part name	Material
1	body	galva. carbon steel
2	disc	galva. carbon steel
3	O-ring	NBR
4	O-ring	NBR

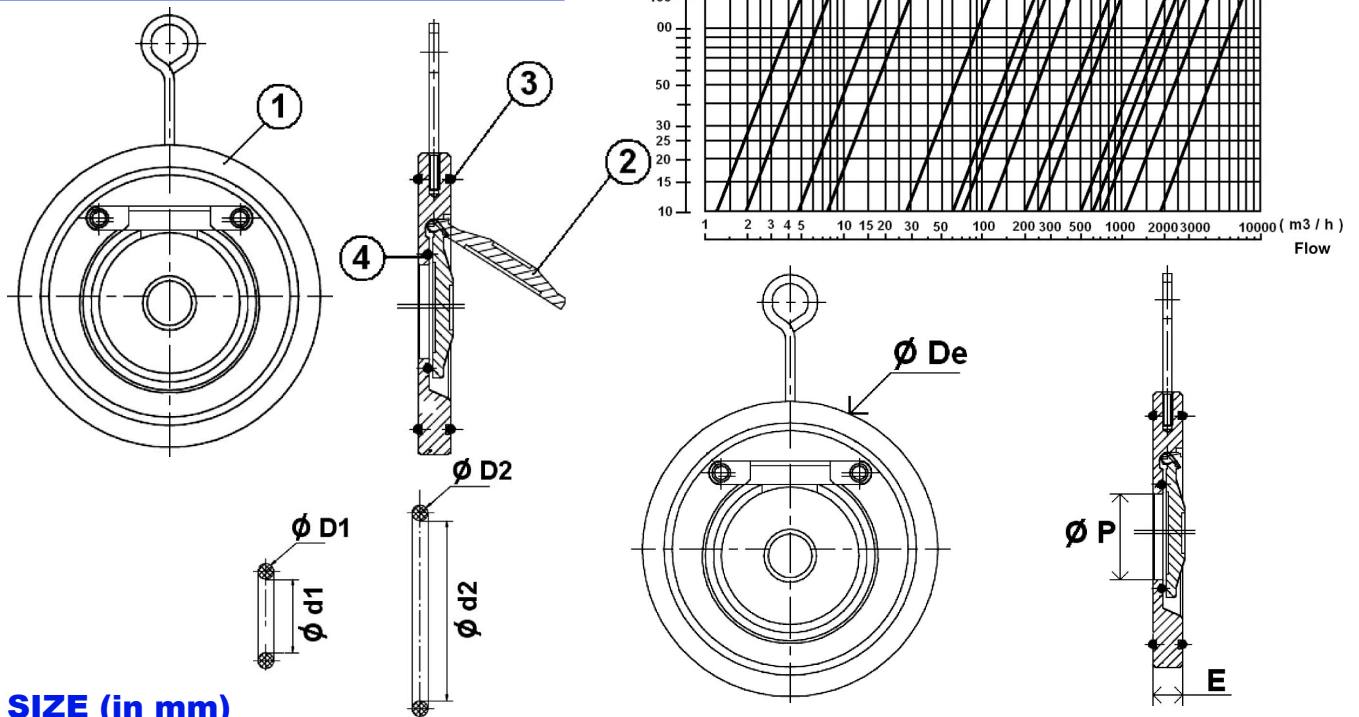

SIZE (in mm)

DN	40	50	65	80	100	125	150	200	250	300	350	400	450	500
E	14	14	14	14	18	18	20	22	26	32	36	41	50	56
De	94	109	129	144	164	194	220	275	330	380	442	494	554	616
P	22	32	40	54	70	92	112	154	192	227	270	315	359	410
d2	72	83	100,6	108,6	138,6	163	189,1	245,1	293,5	338,5	385	435	486	534
D2	3,5	3,5	3,7	3,7	3,7	3,5	3,7	3,7	3,5	6	8	8	8	8
d1	25,3	35,3	46,6	59,6	74,6	96	116,5	161,5	200,5	238,5	283,2	328,2	375,2	426,2
D1	2,35	2,35	2,7	2,7	3,7	3,5	3,5	3,5	3,5	6	8	8	8	8
kg	0,69	0,86	1,2	1,49	2,42	3,29	4,72	7,92	13,73	21,04	31,5	47	70	96
ref.	782B.08	782B.09	782B.10	782B.11	782B.12	782B.13	782B.14	782B.16	782B.18	782B.20	782B.22	782B.24	782B.26	782B.28