



Weyn-Lauwers N.V.

Industriepark-Noord 12
B - 9100 SINT-NIKLAAS

Tel. : 00 32 (0)3 776.34.13
Fax : 00 32 (0)3 778.09.52
weynlauwers@weynlauwers.be
www.weynlauwers.be

**DOUBLE PLATE
CHECK VALVE
CAST IRON
fig 785T**

DESIGN FEATURES

- **wafer type check valve** dn50 - dn600 PN10/16/25
- temp : -10°C +90°C
- specifications :
double plate check valve, epoxy coating
horizontal- or vertical with ascendent fluid position
flanged PN25 up to DN200, PN10/16 above

USE

- for all common fluids, do not use with pulsatory speed
- 16 bar up to dn300 / 10 bar for dn350 - dn600

MATERIALS

item	Part name	Material
1	body	cast iron
2	disc	ductile iron
3	seat	NBR
4	shaft	SS 304
5	spring	SS 316
6	nut	SS 304
7	disc bearing	PTFE

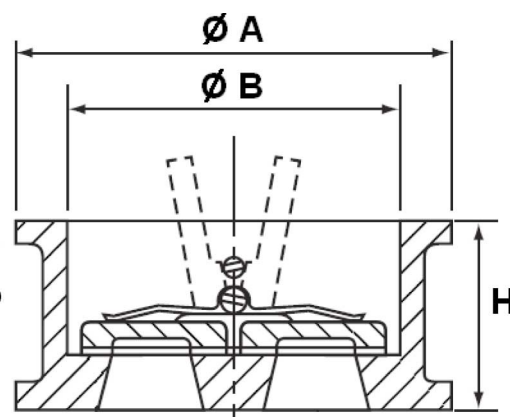
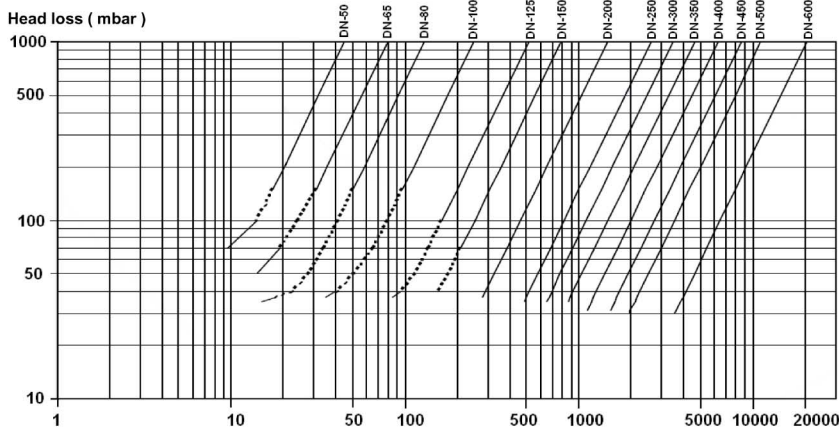
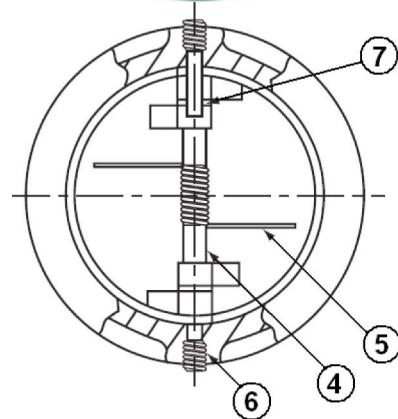
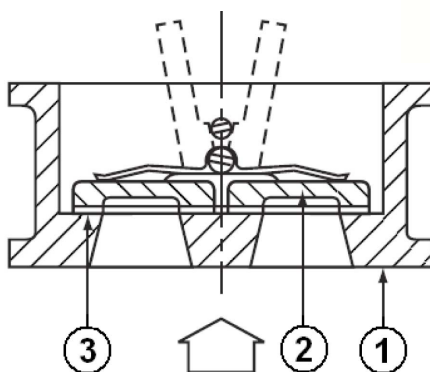

OPENING PRESSURE (mbar)

DN	50	65	80	100	125	150	200	250	300
horizontal position	230	94	190	280	160	79	41	38	31
vertical ascend. fluid	260	114	230	320	180	95	57	58	56

SIZE (in mm)

DN	50	65	80	100	125	150	200	250	300	350	400	450	500	600
H	54	54	57	64	70	76	95	108	144	184	191	203	213	222
B	70	83	90	115	142	169	219	273	324	356	406	467	514	616
A	109	129	144	170	196	226	285	330	380	440	491	541	596	698
kg	1,84	2,40	3,35	5,05	6,68	9,60	18,1	26,9	38,9	80,0	106	128	158	225
ref.	207111	207112	207113	207114	207115	207116	207117	207118	207119	785T.22	785T.24	785T.26	785T.28	785T.30