

**Weyn-Lauwers** N.V.

Industriepark-Noord 12  
B - 9100 SINT-NIKLAAS

Tel. : 00 32 (0)3 776.34.13  
Fax : 00 32 (0)3 778.09.52  
weynlauwers@weynlauwers.be  
www.weynlauwers.be

**FOOT CHECK VALVE  
PN16  
FIG 795**

**DESIGN FEATURES**

- cast iron foot check valve dn50 - dn250 PN16
- temp : -10°C +110°C
- specifications :
  - low head loss
  - all positions
  - epoxy painting blue / steel strainer

**USE**

- water distribution
- flanges PN16

**MATERIALS**

item	Part name	Material
1	body	cast iron EN GJL-250
2	guide	cast iron EN GJL-250
3	bushing	bronze
4	spring	inox 304
5	gasket	EPDM
6	disc	inox 304
7	stem	inox 316



fig 787



fig 795

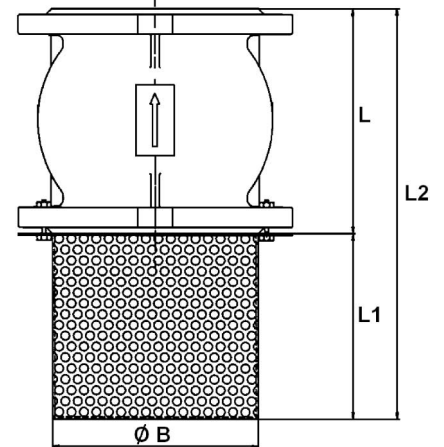
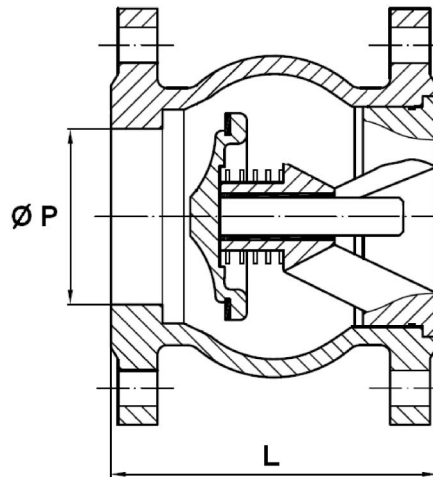
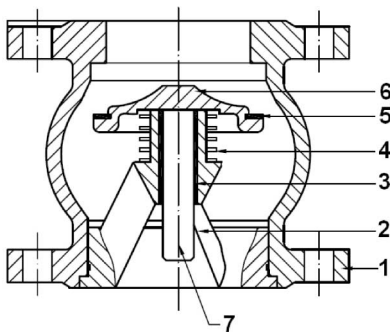

**HEAD LOSS GRAPH**

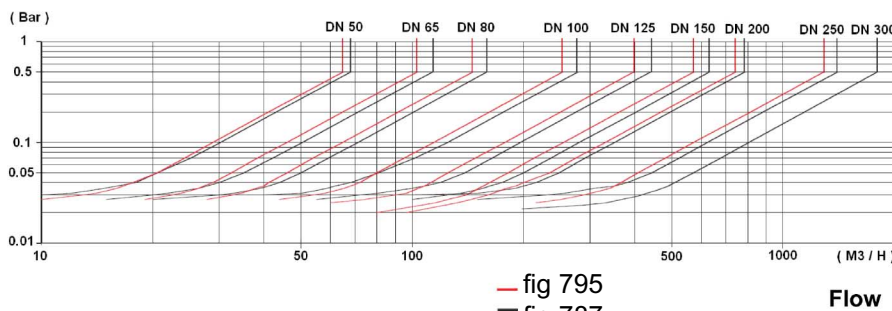

**SIZE (in mm)**

DN	50	65	80	100	125	150	200	250		
P	56	65	81	105	125	150	200	250		
L	100	120	135	165	200	231	288	354		
L1	77	110	125	155	170	220	300	390		
L2	177	230	260	320	370	451	588	744		
B	93	113	128	148	178	200	255	310		
mesh	6	6	6	6	6	6	6	6		
kg	6,59	9,76	11,83	16,70	24,99	36,30	59,28	101,9		
ref.	205061	205062	205063	205064	205065	205066	205067	206068		